

The background is a dark teal color with a pattern of lighter teal diagonal lines and several large, semi-transparent teal circles of varying sizes scattered across the page.

Optics  
**Shinland**

Each Ray is brighter in Shinland

# SL-PL-AG-035A

## Details

Material:	PC
Process:	Injection
Diameter:	35mm
Heigh:	18.5mm
Matched Holder:	Shinland's series A holders
Matched Cover:	None
ROHS Compliant:	YES
Status:	Ready

## Optical Properties

Code	Typ. Angle	Typ. efficiency
SL-PL-AG-035A-S	18°	85%
SL-PL-AG-035A-M	24°	88%
SL-PL-AG-035A-F	34°	88%

## Photo



## Matched LED type

- CLU028
- CLU701
- CLU0B0
- CXM-6
- CHM-6
- CXA13
- CXB13
- CXA15
- CXB15
- V6
- E6
- V8
- E8
- blx C6
- blx C8

# Dimensional Figure

Measure Unit : mm

SL-PL-AG-035A-S

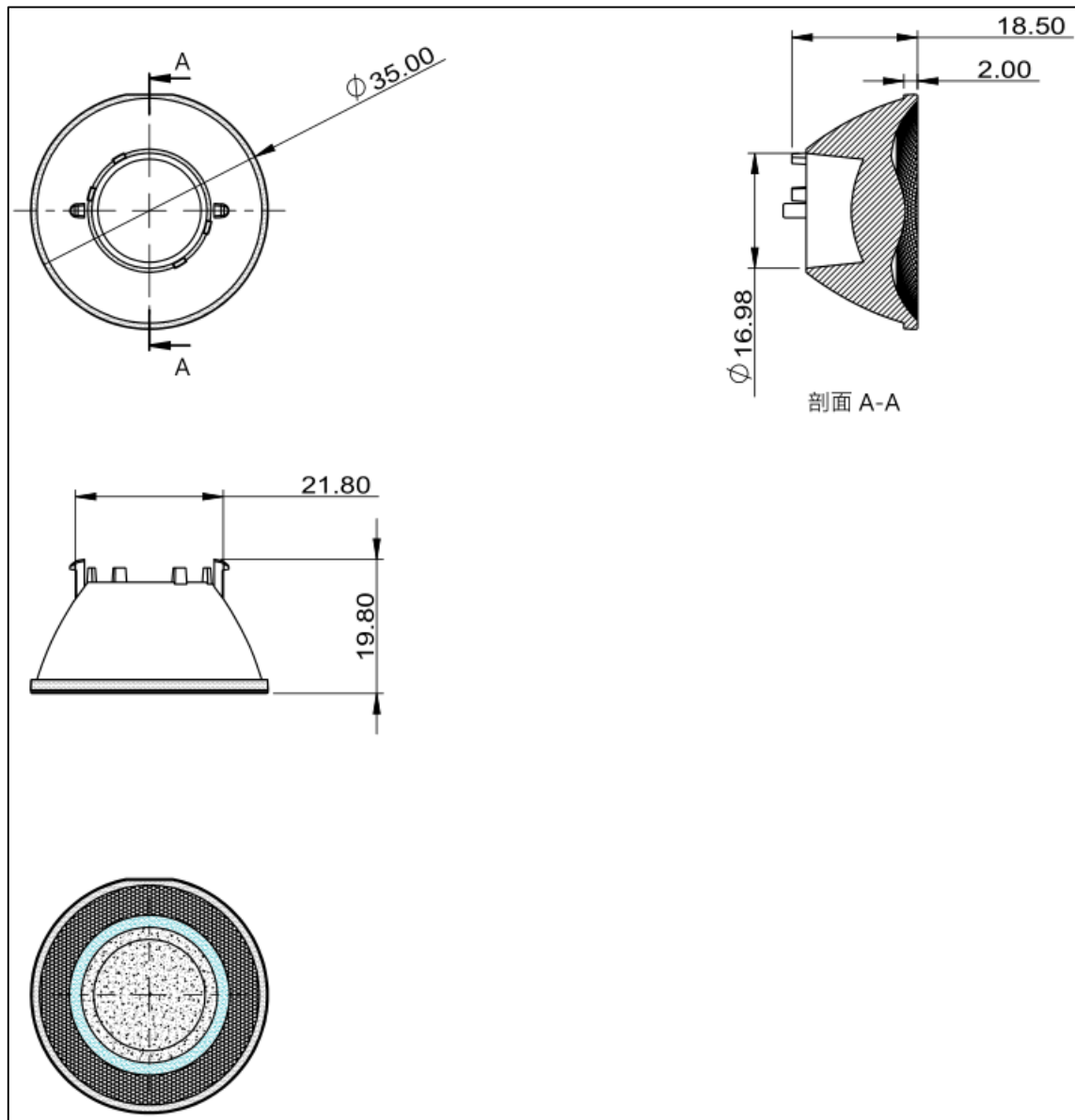

SL-PL-AG-035A-M

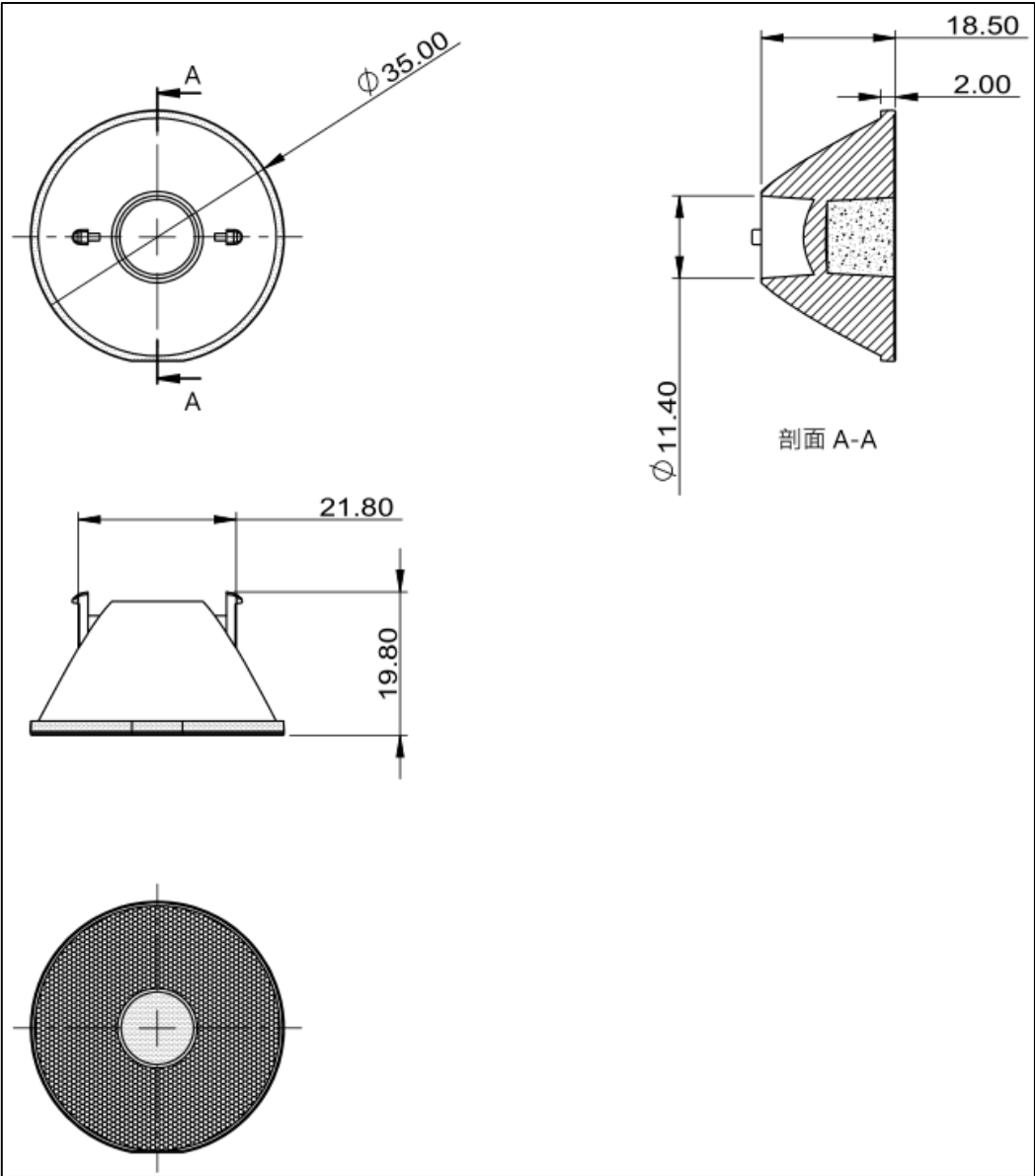

SL-PL-AG-035A-F

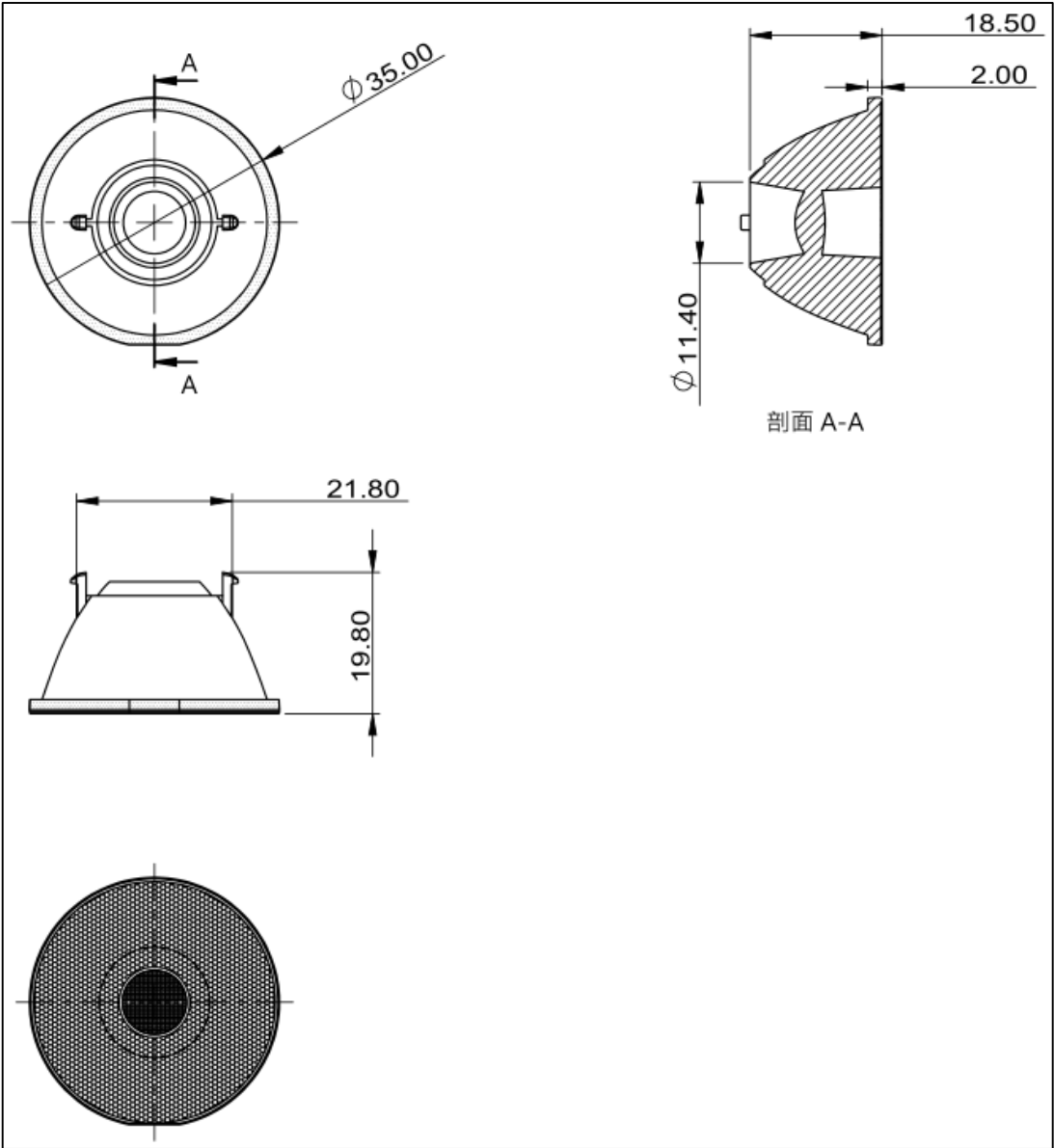

# Distribution Curve Flux

Source:Cree CXA1304

SL-PL-AG-035A-S

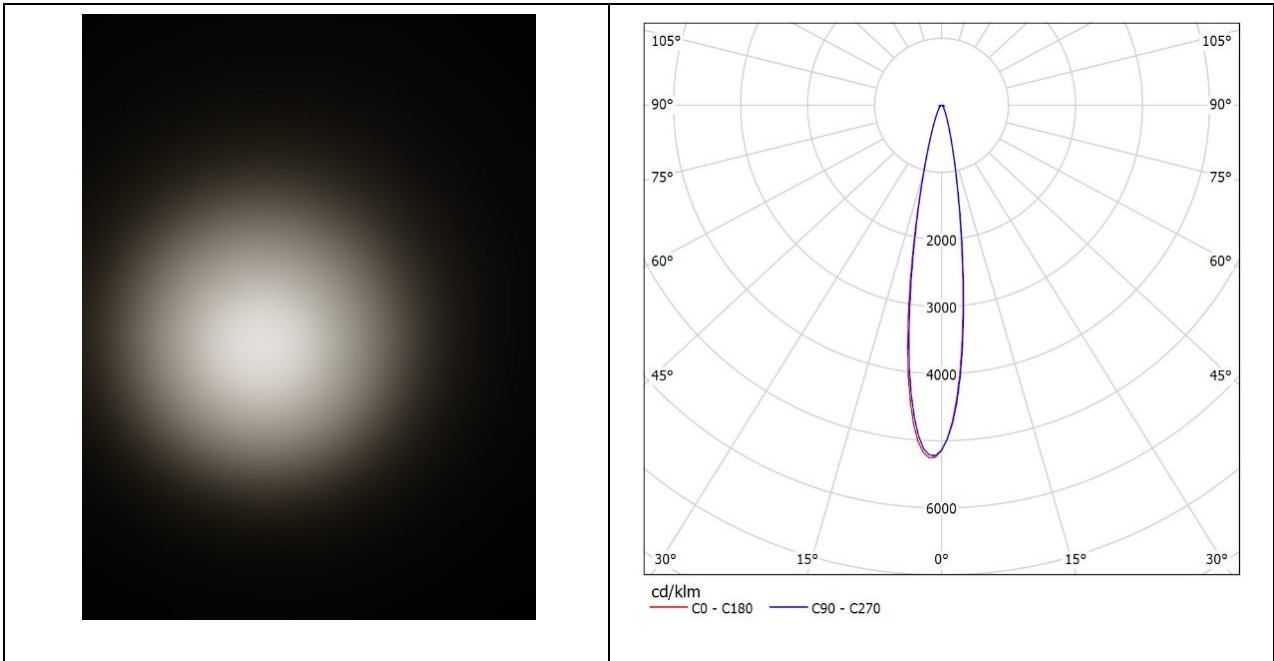

Source:Cree CXA1507

SL-PL-AG-035A-M

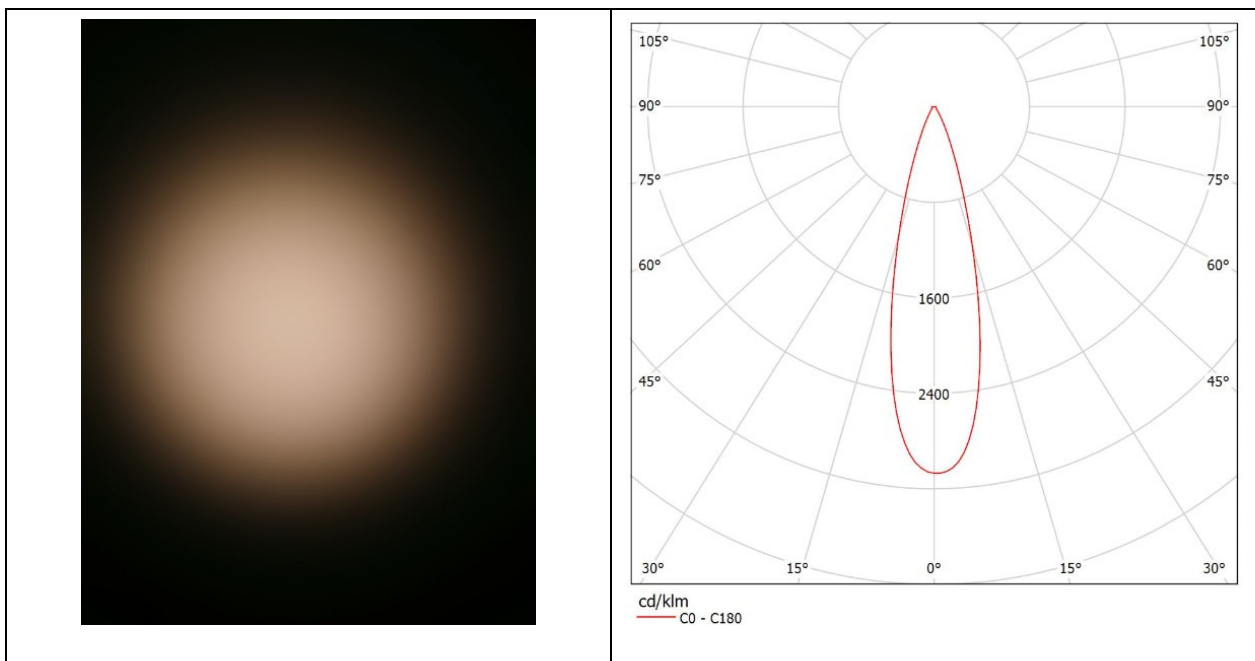

# SL-PL-AG-035A-F

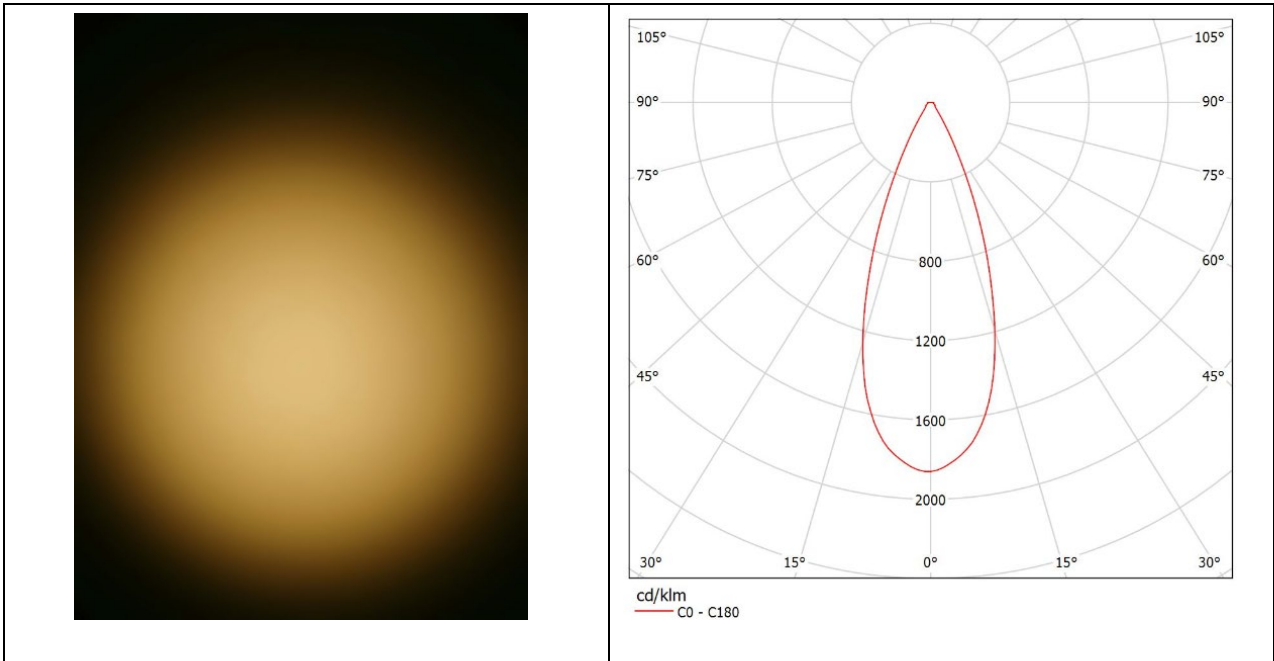

## Notes

- It is not allowed to scrub the reflective surface. If there is dust on the surface, please clean by soft cotton with little water.
- It is forbidden to clean with industrial solvent such as ethanol.
- Storage temperature: 0°C-40°C, and humidity:30%-95%.
- Recommended operating temperature (PC) is <100°C.
- Keep reflector in package to void the dust.
- Prohibit the reflector touch with acid or alkaline solvent.

## About Shinland

Shenzhen Shinland Co. Ltd, one of the longest and most professional company in reflector field, have years experience. Different from other factory which only have simple process, all aspects included R&D, making mold, mass production and market support are achieved by our exclusive resources.

Insisting on “Quality First, Service First” and pragmatic, enterprising spirit, building the market by quality, casting our brand by credibility and integrity, Shinland now become the leading supplier of second-optical solution in China.