

The background is a dark teal color with a pattern of lighter teal diagonal lines and several large, semi-transparent teal circles of varying sizes scattered across the page.

Optics  
**Shinland**

Each Ray is brighter in Shinland

# SL-PL-AG-020A

## Details

Material:	PC
Process:	injection
Diameter:	20mm
Heigh:	15mm
Matched Holder:	SL-HD-AE-022A
Matched Cover:	None
ROHS Compliant:	YES
Status:	Ready

## Optical Properties

Code	Typ. Angle	Typ. efficiency
SL-PL-AG-020A-S	15°	90%
SL-PL-AG-020A-M	24°	90%

## Photo



## Matched LED type

XP-E  
XP-G  
XPE-2  
XPG-2/3  
XHP35-HI

# Dimensional Figure

Measure Unit : mm

SL-PL-AG-020A-S

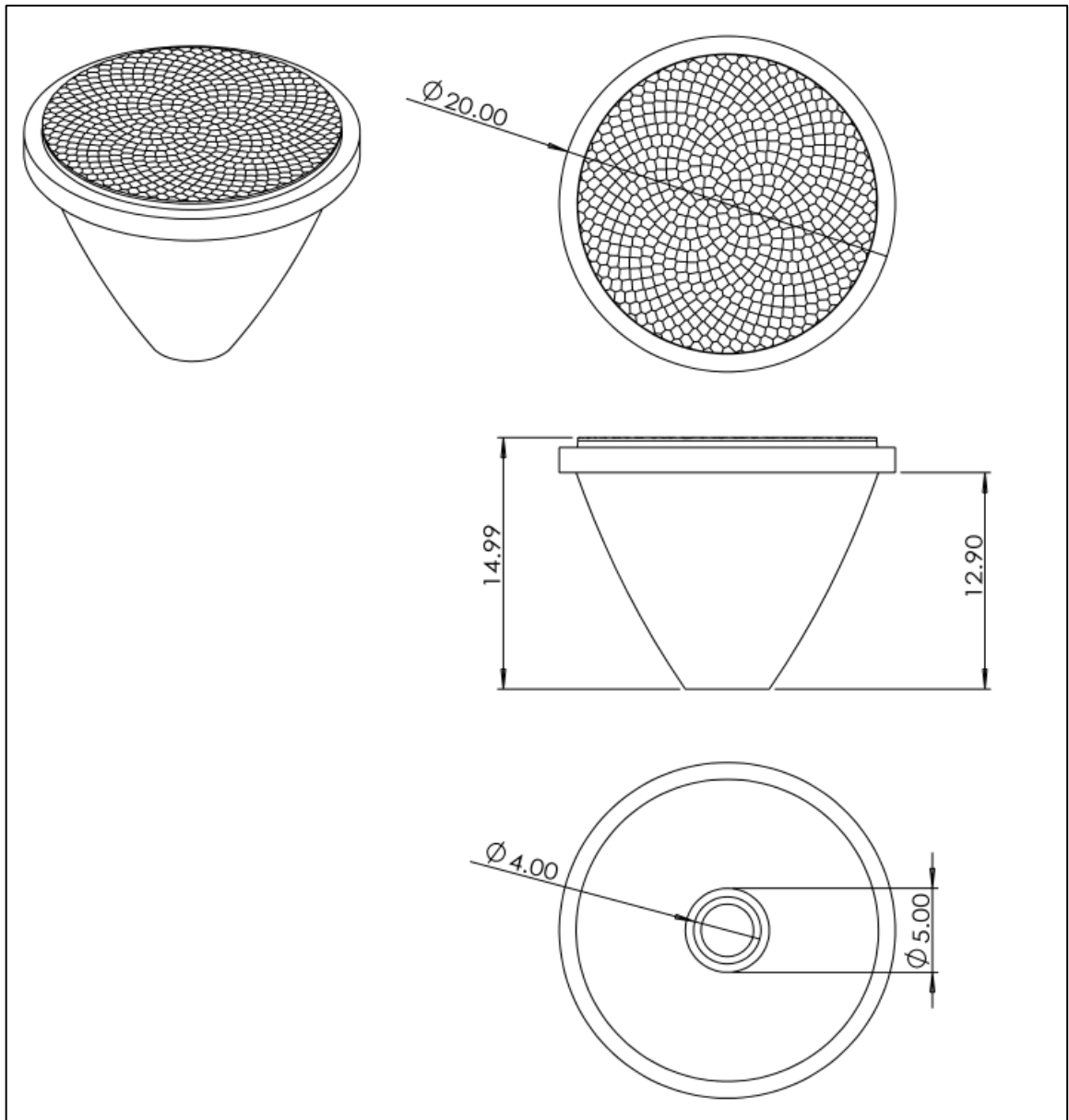

SL-PL-AG-020A-M

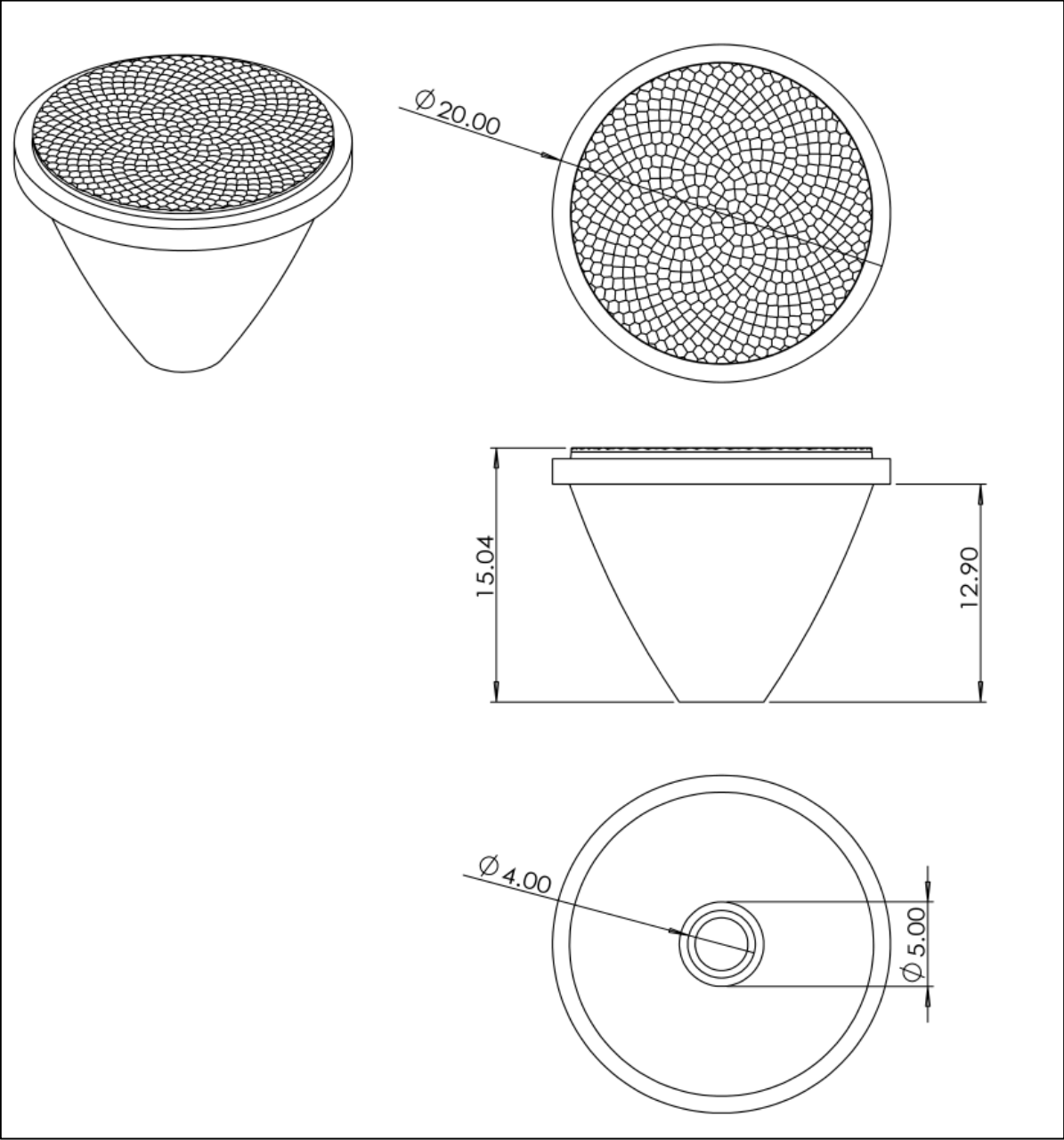

## Matching Steps

Dimension of the hole : 20mm

Depth : 15mm

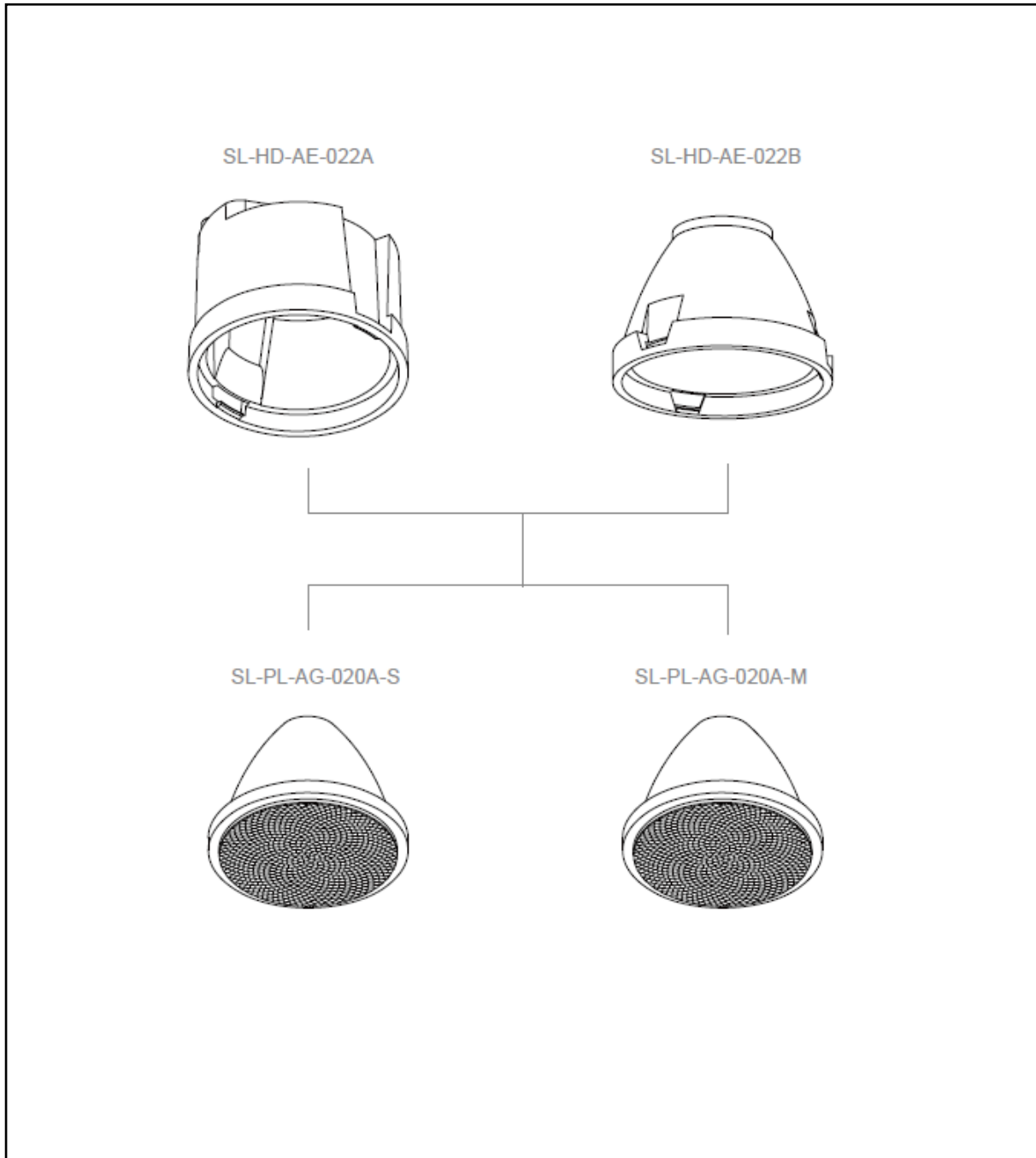

# Distribution Curve Flux

Source:CREE XPG-2

SL-PL-AM-020A-S

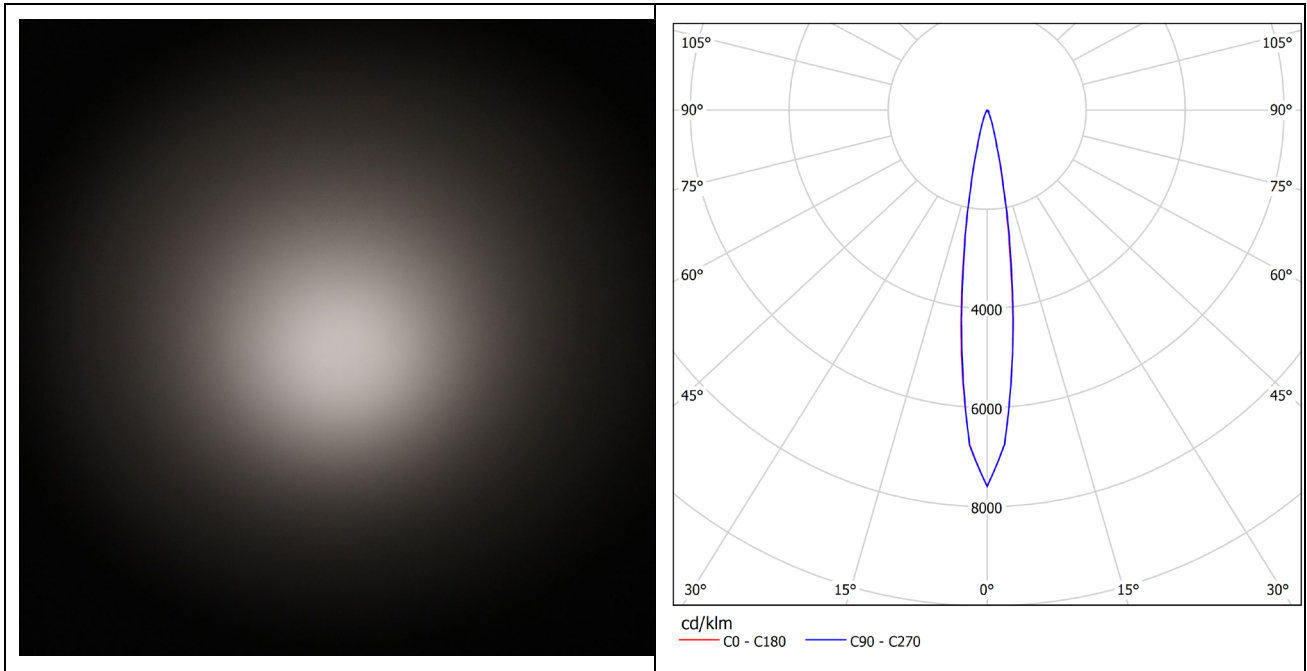

SL-PL-AM-020A-M

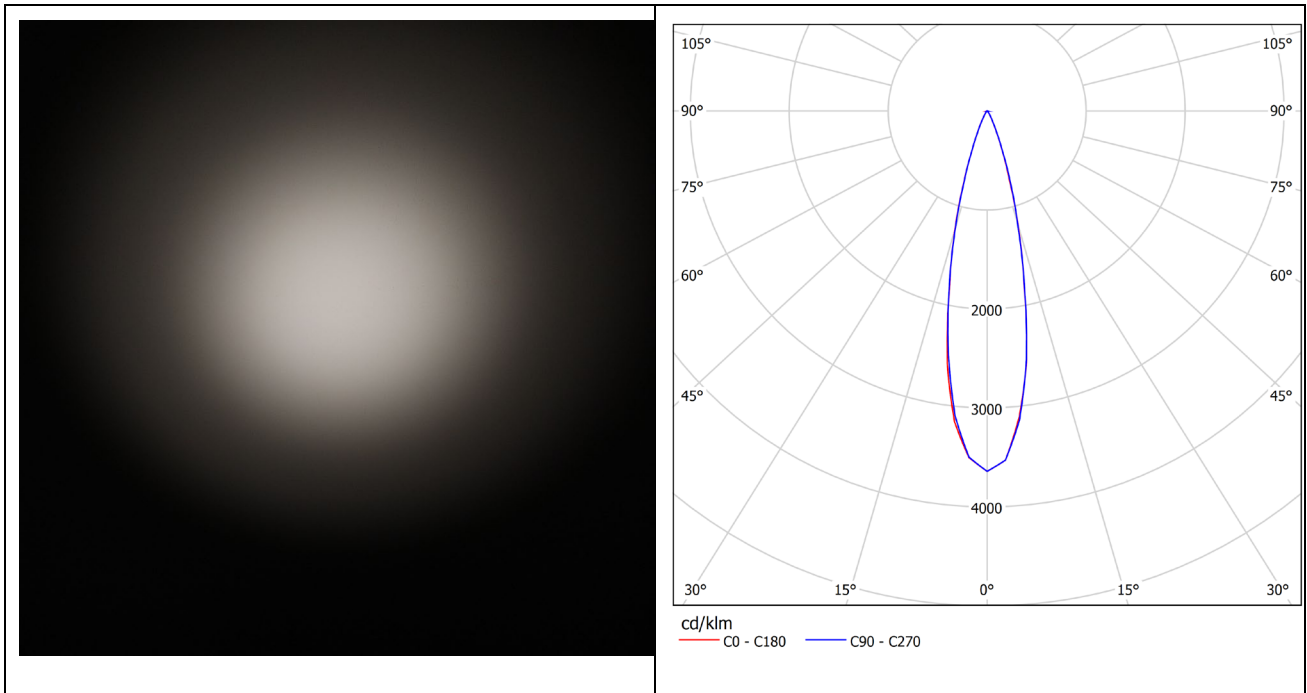

## Notes

- It is not allowed to scrub the optical surface. If there is dust on the surface, please clean by soft cotton with little water.
- It is forbidden to clean with industrial solvent such as ethanol.
- Storage temperature: 0°C-40°C, and humidity:30%-95%.
- Recommended operating temperature (PC) is <100°C.
- Keep reflector in package to void the dust.
- Prohibit the reflector touch with acid or alkaline solvent.

## About Shinland

Shenzhen Shinland Co. Ltd, one of the longest and most professional company in reflector field, have years experience. Different from other factory which only have simple process, all aspects included R&D, making mold, mass production and market support are achieved by our exclusive resources.

Insisting on “Quality First, Service First” and pragmatic, enterprising spirit, building the market by quality, casting our brand by credibility and integrity, Shinland now become the leading supplier of second-optical solution in China.